

GENERAL CHARACTERISTICS

The sensor consists of a rotor vane that is rotated by the speed of the flowing medium. The speed of rotation is proportional to the volume flow per unit time. The signals are relayed by a variety of sensors, depending on the housing materials employed.

- * simple and economical flowmeter for pipe diameters from 32mm to 150mm
- * produced in plastic (stainless steel optional)
- * Quickly fitted using the clamp mount. Even retrospective fitting is easy!

Assembly clamp, assembly screwed-in probe, assembly welded pruning



RRI-032RMH000

RRI-032MHH065

TECHNICAL DATA

DN	Type	Qmax. recom. l/min	metering range l/min H ₂ O			pulse/ litre (6)	frequency Hz of full scale (10)	weight kg
			(1)	(2)	(3)			
32	RR.-032MH032	220	15 - 200	30 - 200	15 - 30	90	300	0.8
40	RR.-032MH040	360	15 - 300	60 - 300	15 - 60	48	240	0.8
50	RR.-032MH050	480	25 - 400	80 - 400	25 - 80	34	227	0.9
65	RR.-032MH065	600	40 - 500	100 - 500	40 - 100	24	200	1.2
80	RR.-032MH080	840	50 - 700	100 - 700	50 - 100	17,5	204	1.3
100	RR.-032MH100	1200	85 - 1000	100 - 1000	85 - 100	10,5	175	1.4

The measurements were taken from left to right with the sensor stationary using water at 25°C.

- (1) **measuring range total**
- (2) **measuring range specified**
- (3) **measuring range non linear**
- (4) **extended operating range**
increase abrasion, Δp > 0.5 bar
- (5) **pulse/litre** (specification on the identification plate on each sensor)
- (6) **average pulse/litre**
- (7) **tolerance ±3%** of the measured value
- (8) **variation ±10%** of pulse/litre data (5) in the charge
- (9) **reproducibility (±1% of full scale)**
is the repetitive accuracy of frequency related to l/min
- (10) **frequency max.** related to the applicable measuring range up to approx 0.5 bar pressure loss over the Sensor

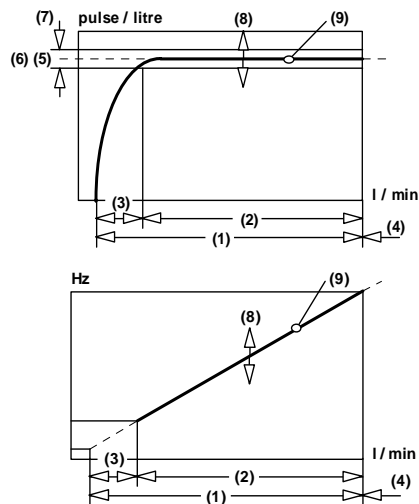

media temperature plastic max.60°C , stainless steel max.100°C
pressure PN10

MATERIALS

	RRI (inductive sensor)	RRH (hall sensor)
housing	plastic PVC	stainless steel 1.4305
assembly clamp	plastic PP	plastic PP
rotor	PVDF / stainless steel 1.4310	PVDF / magnet
bearings	Iglidur X	Iglidur X
axle	ceramic Zr02-TZP	ceramic Zr02-TZP
seal	viton	viton
no medium contact	PVC cable	PVC cable
	brass Ms58 nickel plated	brass Ms58 nickel plated

DIMENSIONS

assembly clamp saddle with pipe and sleeve RR.-032MH...

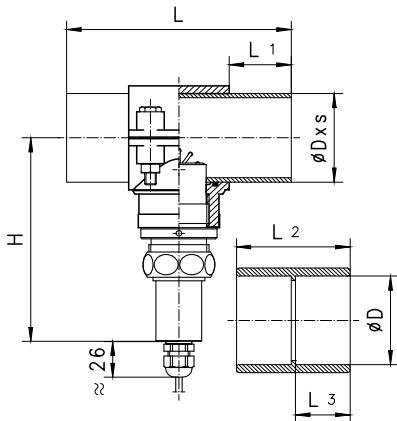

nominal diameter	D	s	H	L	L1	L2	L3
DN 32	40	1,9	145	132	31	55	26
DN 40	50	2,4	145	142	36	65	31
DN 50	63	3,0	145	156	43	79	38
DN 65	75	3,6	154	178	49	92	44
DN 80	90	4,3	156	202	56	107	51
DN 100	110	5,3	166	232	66	128	61
DN 125	140	6,7	172	287	81	159	76
DN 150	160	7,7	180	312	91	180	86

assembly clamp saddle RR.-032BB...

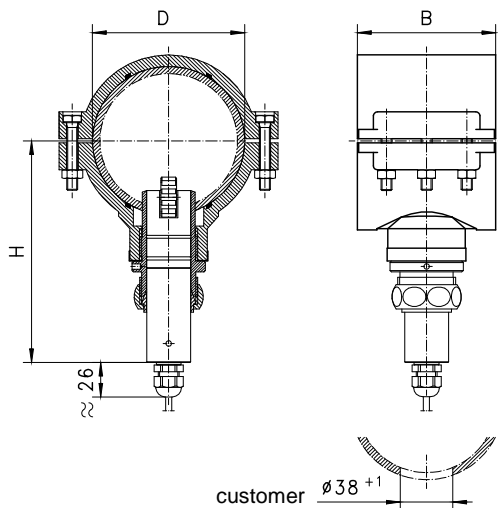

nominal diameter	D	B	H
DN 50	63	70	145
DN 65	75	80	164
DN 80	90	90	156
DN 100	110	100	166
DN 125	140	125	172
DN 150	160	130	180

assembly welded pruing RR.-032RM...

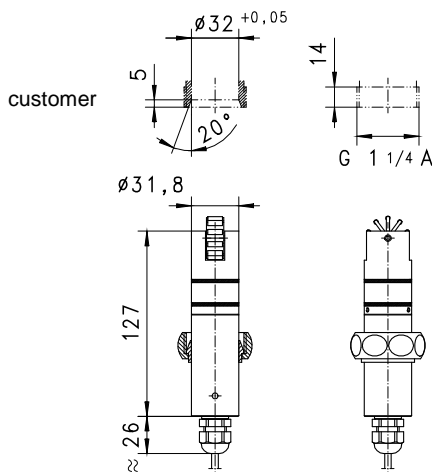

assembly screwed-in probe RR.-032VK...

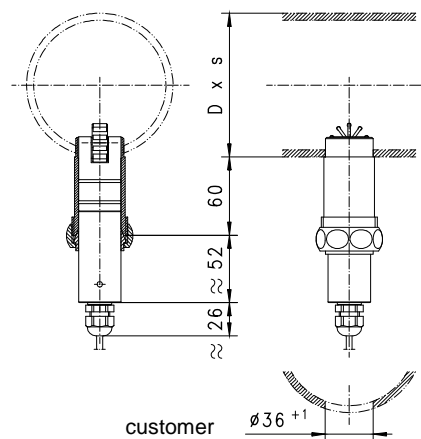

MOUNTING

The Flowmeters are mounted as probes in a T-piece or in a mounting clamp; and marked for the correct insertion depth. The sensor mounting direction is longitudinally to the turbine wheel and is marked with arrows on the face of the probe. (With the electronics mounted, the direction of flow is longitudinal to the electronics housing. A deviation of up to $\pm 3^\circ$ in the angular orientation does not affect the measurement. The sensor must be mounted with inlet and outlet sections of approx. 10 x the pipe diameter to avoid swirls and turbulence. The best mounting orientation (low contamination, good venting) is for upward flow direction or horizontal pipe route and an inclined sensor position of 45° .

ELECTRICAL DATA

supply voltage
quiescent current consumption
max. output current
sensor connection
short-circuit proof
reverse polarity proof
protection class

RRI (inductive sensor)
PNP/NPN 5..30 VDC
Namur 7..12 VDC
10mA / Namur max. 7mA
200mA / Namur max. 7mA
2m cable or connection at locking plugs M12x1, 4-pole
yes
yes
IP67

RRH (hall sensor)
PNP/NPN 10..30 VDC
Namur 7..12 VDC
30mA
100mA
2m cable or connection at locking plugs M12x1, 4-pole
yes
yes
IP67

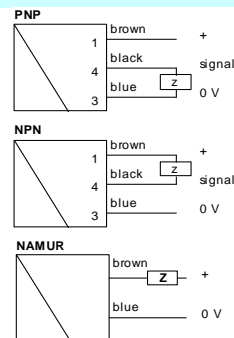

MOUNTING POSITION

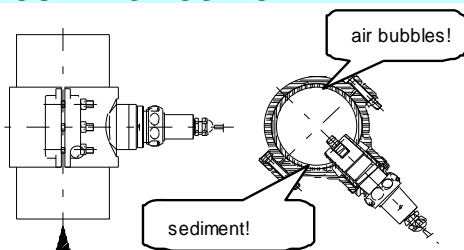

The pipe which accepts the Flowmeter should be completely filled under all operating conditions since air bubbles significantly affect the measurement results. With filling processes the valve should be fitted after the sensor. You should allow for a run-up time of approx. 0.5 s and a delay time of several seconds.

METERING SUBSTANCES

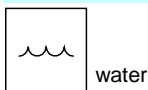

NOMENCLATURE

RRI-	032	MH	H	032	V	10K	P	K	basic type specification
RRI-									● Flowmeter with inductive sensor
RRH-									● Flowmeter with hall sensor
	032								● screwed cap G1 1/4
		MH							● clamp saddle with pipe and sleeve at PVC
		RM							● screwed-in probe G1 1/4 with clamp ring and screwed cap
		BB							○ clamp saddle PP
		VK							○ welded pruning stainless steel 1.4305
			H						● probe material PVC
			K						● probe material stainless steel 1.4305
				000					● (at screwed-in probe or welded pruning)
				032					● DN 032
				040					● DN 040
				050					● DN 050
				065					● DN 065
				080					● DN 080
				100					● DN 100
				125					● DN 125
				150					● DN 150
					V				● seal Viton
					E				○ seal EPDM
					N				○ seal NBR
						10K			● rotor with 10 stainless steel clamps (RRI)
						10T			○ rotor with 10 titanium clamps (RRI)
						05M			● rotor with 5 magnet (RRH)
							P		● PNP output
							N		● NPN output
							A		○ Namur output
							E		● output at suburb electronics (e.g. omni-RR)
								K	● 2 m cable
								S	○ connection at locking plugs M12x1, 4-pole

special applications: Switching output, frequency converter, current output and omni/flex processor

All technical changes reserved

●BASIC Standard ○BASIC Programme option □VARIO Special option ⊕ PLUS Accessories ✗not recommendable