



- * ideally suitable for liquid/liquid applications
- * can also be used for high differential pressures
- * high chemical resistance through the use of high quality materials
- * head can be turned for alignment after installation
- * analogue output, frequency output, switching outputs
- * clear, easily readable, backlit LCD display
- * changeable units in the display
- * designed for industrial applications
- * small and compact
- * most simple installation

PRINCIPLE

The differential pressure measurement cell is manufactured with two separate ceramic sensors in thick-film technology. The bridge signals are temperature compensated on the relevant cell. The medium is exposed to high quality materials only such as Al₂ ceramic, stainless steel and Viton O-rings and is therefore ideally suitable for liquid/liquid applications. Please take all additional data from the omni-sensor-family 51.1.omni and data sheet 51.1.omni2.

TECHNICAL DATA

operating ranges	relativ pressure		
overload limits	range	overload	burst
burst pressure (bar)	0 - 1	3	4
	0 - 2	6	8
	0 - 5	15	20
	0 - 10	30	40
	0 - 20	60	70
	0 - 50	150	180
	0 - 100	200	350
	0 - 200	400	600
differential pressure range	to be specified by customer minimum: 10% of operating range maximum: operating range		
accuracy	±1% FSD		
operating temperature	0..70°C (with goose-neck max.85°C)		
storage temperature	-20..80°C		
supply voltage	18...30 VDC		
power consumption	<1 W		
output	4(0)..20mA, 2(0)..10V across 500 Ohm resistor to 0V.		
switching values S1 and S2	PNP or NPN selectable, 300mA load in sum max., programmable as min. or max. value, short-circuit proof, reverse-polarity proof		

hysteresis	adjustable, position of hysteresis depends on min or max.	
display	graphical LCD display extended temperature range -20..70°C, 32x16 pixels, back-lit, shows value and units, LED signalling lamp with simultaneous message in display.	
connection	at locking plug M 12x1, 5-pole	
protection class	IP67	
materials	stainless steel 1.4571, Viton, ceramic Al ₂ O ₃	
medium contact	housing stainless steel 1.4305 glass tempered mineral glass magnet cobalt samarium ring POM	

Please take all additional data from 35.1.EDP1.

TERMINAL ASSIGNMENT

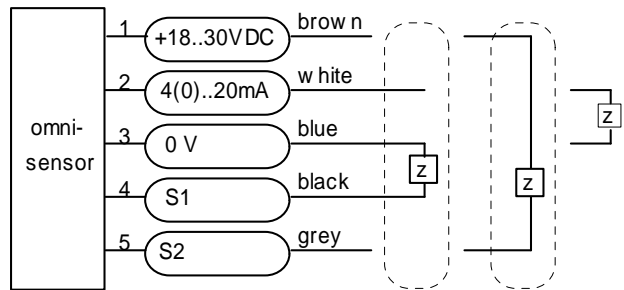

Example: PNP or NPN

Z = load

The switchpoints are changing to PNP or NPN depending to your interface automatically.

Signal output with 2(0)..10V
Sample:

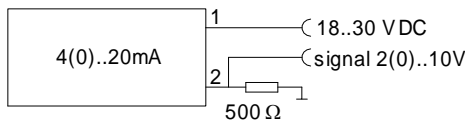

MOUNTING

Join your pipework to P1 and P2 (see also Accessories). When sealing, ensure cleanliness during assembly. The standard version is designed for P1>P2, but a defect does not occur if the connections are interchanged).

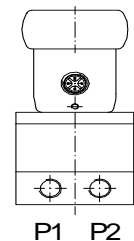

If you need to clean the pressure cells from the wetted side, you only have to undo the screws of the sensor housing, the electronic remains closed. Cleaning must be carried out very carefully with a cotton bud, avoiding liquid particles between cell and electronic component.

DIMENSIONS

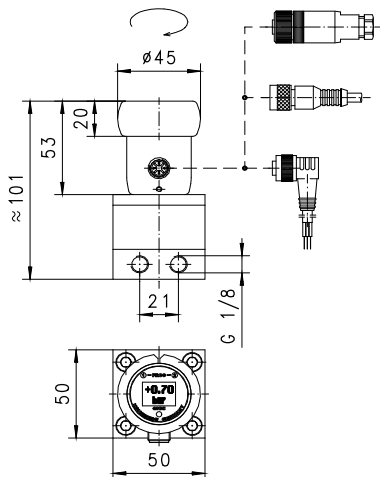

locking plug M12x1, 5-pole
(accessory)

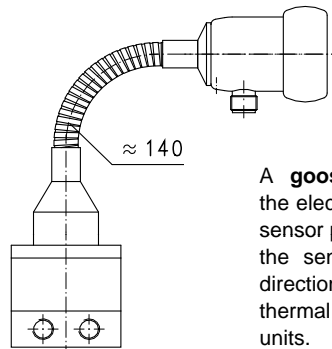

A **goose-neck** (optional) between the electronics head and the primary sensor provides complete freedom in the sensor alignment and reading direction. This option also gives thermal decoupling between both units.

NOMENCLATURE

omni-DP1	001	R	0001	K	004	S	H	basic type specification		
	001							●	Range of the individual cell	0 - 1 bar
	002							●		0 - 2 bar
	005							●		0 - 5 bar
	010							●		0 - 10 bar
	025							●		0 - 25 bar
	050							●		0 - 50 bar
	100							●		0 - 100 bar
	200							●		0 - 200 bar
		R						●		relative pressure
			0001					●		Differential pressure range - example 0055 = 5.5 bar (min. 10%, max. 100% of nominal pressure range)
			...					●		
			2000					●		
				K				●	material parts in contact with the medium stainless steel 1.4571	
					004			●	connection G1/8	
						S		●	connection for locking plug M12x1, 5-pole	
							H	○	goose-neck	

INFORMATION

the same sensor transducer is also available with a display as a standard 4..20mA sensor in two-wire technology see product information 45.1.EDP1.

ACCESSORY

Locking plug M12x1

K5	PU-	02	S	G	basic type specification	
K5					●	ready-made cable 5-pole
KB05					●	self makable cable 5-pole
	PU-				●	material PUR
		02			●	length 2 m
		05			●	length 5 m
		10			●	length 10 m
			S		●	moulded-on plug
				G	●	straight plug
				W	●	angled plug 90°



All technical changes reserved

●BASIC Standard ○BASIC Programme option □VARIO Special option ⊕ PLUS Accessories

✗ not recommendable